



GROB-WERKE

Competence in advanced technology worldwide

CONTENTS



04 **GROB WORLDWIDE**
From internationalization to globalization

06 **IMPRESSIONS FROM AROUND THE GLOBE**
Introducing the plants in Brazil, USA and China

10 **THE COMPANY**
People at the center

11 **PHILOSOPHY**
Basic values developed through family tradition

12 **FAMILY TRADITION**
Measurable success spanning generations

13 **VISION**
Future strategy with certainty

14 **HISTORY**
GROB-WERKE since 1926

16 **OUR CORE EXPERTISE**
Intelligent technology is human

18 **SALES AND PROPOSAL ENGINEERING**
The nucleus of successful ideas and products

19 **ENGINEERING**
Ahead of the times – having reality in sight

20 **MANUFACTURE**
Optimized vertical integration – lead times reduced to a minimum

21 **ASSEMBLY**
Experience and instinct



22 COMMISSIONING
From our production – to your production

23 RESEARCH AND DEVELOPMENT
The details at a glance

24 SERVICE WORLDWIDE
As versatile as our customers' demands

26 TRAINING
Foundation for a successful future

28 INTERNAL DEPARTMENTS
Reliable basis for corporate success



30 UNIVERSAL MACHINING CENTERS
Precision at the highest level

32 SYSTEM SOLUTIONS
The G-series – the flexible manufacturing system

34 ASSEMBLY SYSTEMS
Highly-productive and customer-specific

36 SOPHISTICATED CUTTING-EDGE TECHNOLOGY
Made by GROB

38 OUTSTANDING
Quality – convinces our customers, creates recognition and trust





Company Headquarters in Mindelheim, Germany



GROB – WORLDWIDE – MINDELHEIM (Germany)

From internationalization to globalization

As a global, family-owned company, we have been developing manufacturing systems and machine tools since 1926. Our customers include the world's leading automotive manufacturers, their component suppliers and other renowned companies from diverse sectors. We are represented around the globe with our production facilities in Mindelheim (Germany), Bluffton (Ohio, USA), São Paulo (Brazil) and Dalian (China), as well as our worldwide service and sales branches. We employ around 6,000 people and generate over 1.3 billion euro in revenue from all around the world.

GROB-WERKE has been headquartered in Mindelheim for almost 40 years. With a production space of more than 180,000 m² and over 4,100 employees, our GROB plant in Mindelheim is the Group's largest site and the biggest employer in the region. At this site especially, we have created numerous new and skilled jobs in recent years through enormous production capacity expansions.



IMPRESSIONS FROM AROUND THE GLOBE





São Paulo, Brazil



GROB – WORLDWIDE – SÃO PAULO (Brazil)

Oldest plant in the production network

Since 1956, B. GROB do Brasil has been producing machines for both Brazilian industry and for export. As the oldest plant in the GROB Group, our Brazil branch is an important part and strong partner within the GROB production network. The product range includes both the system business, which focuses on machining centers for transmissions and engines, and also the 4- and 5-axis universal machining centers.

To make sure the success story can continue in the years to come, an astounding 16 million euro were invested in buildings and machinery over four years. Due to continuous process optimizations in production and administration, B. GROB do Brasil has grown even closer to the other GROB plants within the network. This integration will create huge benefits over the next few years as the competition continues to increase.



GROB – WORLDWIDE – BLUFFTON (USA)

North American bridgehead

The optimum location of our GROB plant in Bluffton, Ohio, not only makes it a bridgehead to the North American market, it is also the ideal point of contact for the "Big Three" automotive companies in the USA: Ford, Chrysler and General Motors. Consequently, our GROB Systems Inc. plays a key role in both the GROB production network and also in the world's second largest automotive market.

Machining centers, special-purpose machining units, assembly lines and assembly equipment in machining lines are produced, installed and commissioned here.

In addition to the US market, the GROB plant in Bluffton also supports customers in Mexico and Canada. GROB Systems Inc. has also supplied machines to Germany, China, South Africa and even Uzbekistan through the GROB production network.



GROB – WORLDWIDE – DALIAN (PR China)

Strategic course of action as a foundation stone in Asia

The fourth and latest production plant of the GROB Group in Dalian in China, which was ceremoniously opened on June 18, 2012, safeguards our company's global competitiveness and strong presence in the Chinese market and improves the strategic alignment in the Asian growth region.

Through our commitment in Asia, we are meeting our customers' high expectations and demands way beyond the borders with China. Throughout Asia as a growth region, we have complete expertise in sales, production and service in close proximity to our customers.

Our dealings in China follow a long-term strategy with a clear commitment to the Dalian site.



THE COMPANY

People at the center

We are a global family company with a commensurate culture that has been deeply rooted for generations.

A culture which leads, through focusing on people, to mutual loyalty and a high degree of identification with our employees and customers, hence guaranteeing us a distinct competitive advantage.

A culture of value-based management with a long-term approach, which has developed to become an important part of safeguarding our company's future.

We promise our customers and employees values such as sustainability.

Strategies that will safeguard continuity for our employees all over the world for many years to come are developed from the family tradition.



PHILOSOPHY

Basic values developed through family tradition

- Long-range thinking
- Distinctive customer proximity
- Quality and delivery reliability
- Innovative strength and technological leadership
- Appreciation and commitment vis-à-vis our employees

A philosophy that has helped us win the confidence of our customers and employees again and again during the long history of our company, and has hence enabled us to enhance and consolidate our market position for decades.



FAMILY TRADITION

Measurable success spanning generations

Our success story began back in 1926 when Dr. Ernst Grob founded Ernst Grob Werkzeug- und Maschinenfabrik.

In 1952, the founder's son Dr. Burkhart Grob assumed responsibility for our company and took GROB-WERKE to its leading market position of today.

Even after Dr. Burkhart Grob passed away in May 2016, the future of our family company has been strictly set out. Christian Grob manages the company in the third generation, being the new Supervisory Board Chairman. Already at this early stage, the next generation is being prepared for future tasks.



VISION

Future strategy with certainty

As a dependable partner to the automotive industry, its component suppliers and to the engineering industry in general, we produce innovative and efficient plant and machinery to the highest quality. The customer-oriented alignment of our products in both the system and universal machining center business and service sector has earned us incredible recognition – especially in the automotive industry.

Our steady and constant further development and pursuit of perfection have made us technology leader and trendsetter. As a strategic partner, we have set ourselves the finest goal of cultivating our partnerships and hence the proximity to our customers on the highest level, and to drive forward further expansion. Technical innovations for economic production to the benefit of our customers – that is our motivation.

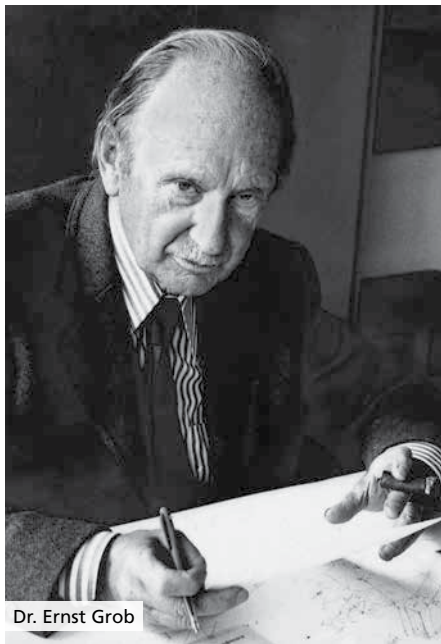

Dr. Ernst Grob



Ernst Grob Werkzeug- und Maschinenfabrik, Munich, 1926



Dr. Burkhard Grob

HISTORY

GROB-WERKE since 1926

- | | | | |
|-------------|----------------------------------------------------------------------------------------|-------------|---------------------------------------------------------------------------------------------|
| 1926 | Company founded in Munich by Dr. Ernst Grob | 1990 | GROB branch founded in Wellesbourne (Great Britain) |
| 1933 | Start of production for thread milling fixtures and machines | 1991 | Bluffton branch (Ohio, USA) expanded to become a production plant with a dedicated facility |
| 1952 | Founder's son Dr. Burkhard Grob assumes responsibility for our company | 2000 | GROB branch founded in Saltillo (Mexico) |
| 1956 | First foreign plant established in São Paulo (Brazil) | 2003 | GROB branch founded in Beijing (China) |
| 1968 | Second German plant established in Mindelheim; Construction of the first transfer line | 2004 | Modular machining centers (G-series) developed by Dr. Burkhard Grob launched on the market |
| | | 2005 | GROB branch founded in Shanghai (China) and Seoul (South Korea) |
| | | 2008 | Market launch of the universal machining center |

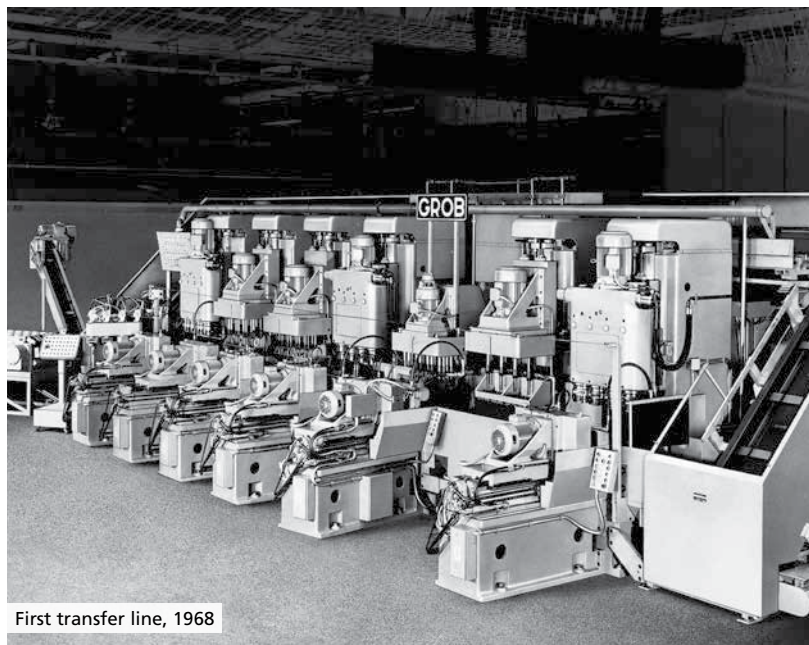

First transfer line, 1968



GROB production line

- 2009** GROB branch founded in Chennai (India)
- 2010** Market launch of the non-hydraulic machining center; Fourth production plant founded in Dalian (China); GROB's Mexican branch relocated to Querétaro
- 2011** GROB branch founded in Moscow (Russia); GROB's Indian branch relocated to Hyderabad; Foundation stone laid for the Dalian plant (China)
- 2012** New milestone in the growth strategy: GROB-WERKE is ramped up for a production capacity of 1 billion euro; GROB service branch founded in Győr (Hungary); June 18, 2012 – GROB Dalian opens
- 2013** GROB's British branch relocated to Birmingham; Construction of a state-of-the-art logistics hall at the headquarters (14,000 m²)

- 2014** New automation hall constructed in the Mindelheim plant (15,600 m²); GROB Mexico opens on its own premises (Querétaro); Completion of the "H12" GROB Training Center in Mindelheim (5,200 m²)
- 2015** In financial year 2014/15, the Group's revenue hits the billion mark; New construction and expansion of the Technology and Applications Center (TAZ) in the Mindelheim plant (on 2,000 m²); GROB-TAZ opens in Shanghai; Construction of the new GROB Group headquarters begins in Mindelheim; GROB branches founded in Turin (Italy) and in Posen (Poland)
- 2016** Completion of the new corporate headquarters and start of construction for a 30,000 m² production hall in Mindelheim; 90 years of GROB-WERKE; B. GROB do Brasil celebrates 60th anniversary; May 20, 2016: Dr. Burkhard Grob passes away; Christian Grob assumes the position of Supervisory Board Chairman and takes the company forward into the third generation
- 2017** Purchase of DMG meccanica, the Italian machine and plant constructor for electric motors

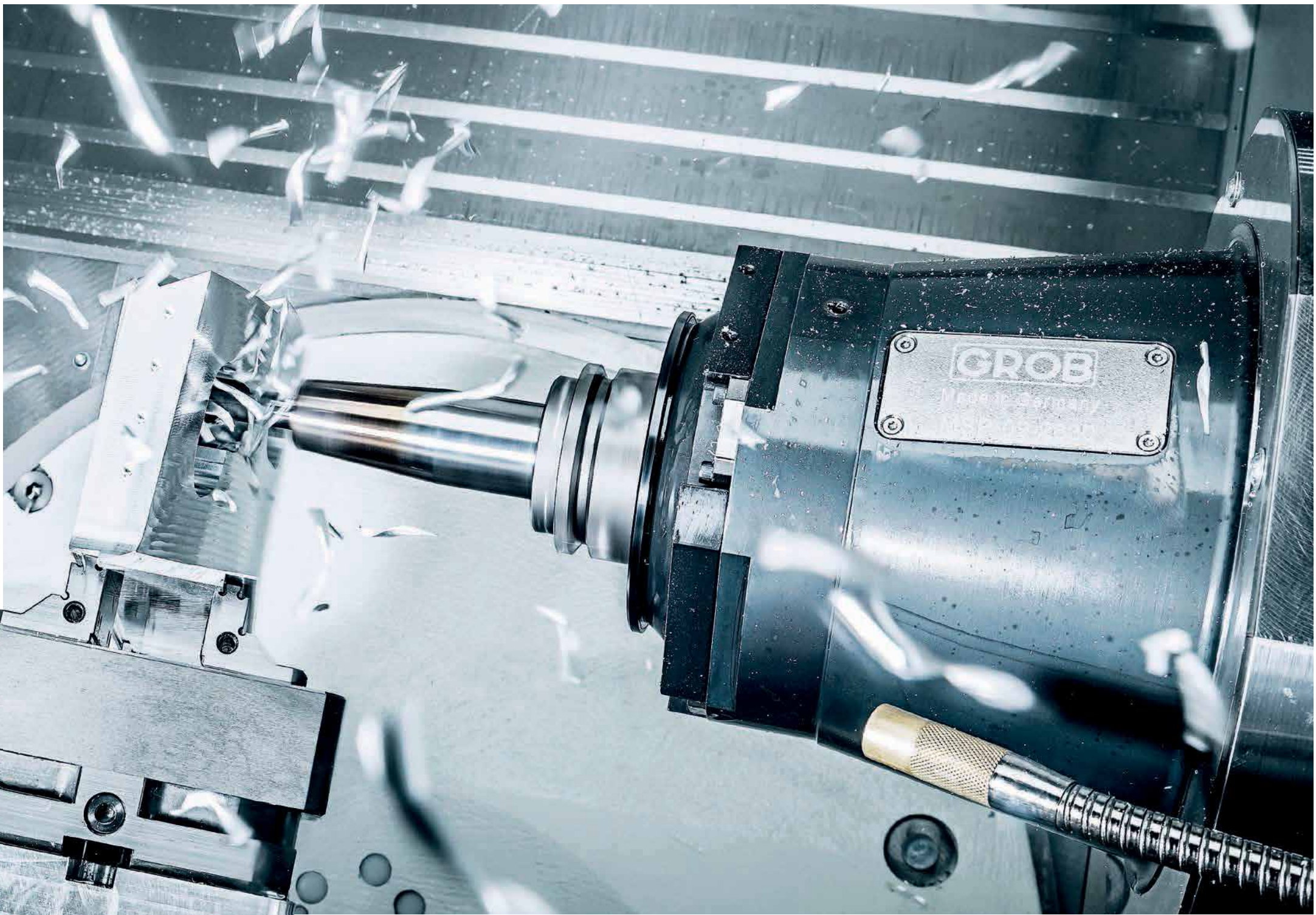



OUR CORE EXPERTISE

Intelligent technology is human

For generations now, we at GROB have lived and experienced this principle by making customer requirements the focus of our work. The result is a sophisticated technology that creates more efficient production processes worldwide and delivers optimum quality.

From the universal machining center to complex production systems to fully automatic assembly units – we offer you the full range of cutting-edge machine tools and system solutions.

Our machining centers and system solutions set the benchmark for precision and reliability, created by our engineers and technicians – GROB expertise at its best.



SALES AND PROPOSAL ENGINEERING

The nucleus of successful ideas and products

To be able to guarantee you an optimal process design in the production of your part, our proposal engineering department will develop a highly-effective concept tailored to your particular requirements and preferences. So you gain benefit from our extensive technical expertise and many years of experience. The global networking of proposal engineering, development, design and service guarantees a continuous improvement process along the entire process chain and guarantees you state-of-the-art GROB products. The close cooperation between the machining, assembly and engineering departments ensures you receive all the products and services you need from a single source.

You will be supported by an experienced team of key account and project managers, who provide you with expert advice throughout your project. As the interface between you and GROB, these managers are ideally networked with all departments involved in the process and communicate your requirements within our organization.



ENGINEERING

Ahead of the times – having reality in sight

Our engineering department – in close collaboration with development – is an important springboard for attaining a competitive edge and success for our company. To meet this challenge, our technicians and engineers satisfy the most diverse requirements.

With a great deal of creativity and lateral thinking, they leave the familiar paths to develop innovative new concepts for you. This is always under the premise of processing your customer order to the given budget and within a standardized kit, while optimizing existing solutions down to the finest detail at the same time. The result are machines and solutions you recognize as a benchmark for precision and reliability. The latest market requirements are considered and analyzed, and hence integrated into the development of new product fields.



MANUFACTURE

Optimized vertical integration – lead times reduced to a minimum

We achieve our claim of "World class production" through various optimization processes, such as segmenting machining sequences, reducing internal throughput times and refining our machining strategies. The high degree of vertical integration along the entire value creation chain, numerous machining technologies and the profound specialist knowledge of our employees create the perfect platform for being able to cater to and respond to your requirements, as GROB customers, in an extremely flexible and independent manner.

"World class production" is our vision of achieving the best possible value creation and hence the most profitable overall result for our company, both in production and assembly.

"Taking responsibility together" is the motto here, along with our claim of producing every single component to the required quality and passing them on to downstream departments without any faults at all.



ASSEMBLY

Experience and instinct

From pre-assembly to machine assembly through to process commissioning – our employees demonstrate their expertise in all aspects of the machining process through optimally-coordinated assembly sequences. Our logistics management ensures the ideal material flow as early as the pre-assembly phase.

Thanks to a modular concept, the high quality of our GROB products is evident already during machine assembly. Our experienced teams apply their sure instinct to amalgamate these machines to form a complete system within just a few working days. Extensive quality checks are an integral part of every assembly step. Process commissioning involves checking the system for its harmonious interplay, the aim being to produce a certain number of parts to the highest possible quality, reliably, economically and within a defined time to guarantee you the best customer benefits.



COMMISSIONING

From our production – to your production

From setting up the machines, portals and automation systems, product acceptance and process capability tests, to disassembly in our production halls through to restarting on your premises – our "Process commissioning, mechanical" ensures a smooth assembly workflow and hence an optimal start of production.

The latest electrical systems, software technology and drive technologies are included in our production plants as standard and are tested by our "Process commissioning, electrical" using a diverse series of tests.

As a result, we deliver perfectly coordinated production lines and machining processes for your on-site facility.



RESEARCH AND DEVELOPMENT

The details at a glance

With a high degree of creativity and technical empathy, as well as the best engineering knowledge, our developers have worked hard to earn the reputation of technology leader in custom machine tools.

However, it is not just the pursuit of new and innovative solutions, such as developing production plants for electric motors, that makes the difference, it is also the constant contact with production and assembly, as well as the daily exchange of experiences with the GROB service team.

For decades now, this is what has been behind the creation of technical highlights such as the G-module series. We attribute special importance to research and development, with the high technological claim which our employees from development feel obliged to meet.





SERVICE WORLDWIDE

As versatile as our customers' demands

For us, service starts with the planning and coordination of machine installation and the associated support for start of production. It spans individually coordinated training services, advice on special equipment and spare and wear parts, optimized use and system reconditioning, through to prompt assistance in case of machine malfunctions in the production process.

This applies in equal measure for all shipments from our production plants in Mindelheim (Germany), São Paulo (Brazil), Bluffton (Ohio, USA) and Dalian (China), as well as from our branches all over the world.

We guarantee top quality and the best service throughout our global GROB service network.

A team of express service technicians is available all over the world 360 days per year – 24 hours a day. The response time, if required, is within one hour.





TRAINING

Foundation for a successful future

Over 1,500 young people who have trained with us in Mindelheim are testimony to the continuous qualification of our own young talent. We offer apprenticeships in various disciplines to anyone interested.

We have recognized the signs of the times and set another milestone with our new "H12" Training Center in Mindelheim to guarantee stability in vocational training and ensure a supply of young professional talent to GROB.

Interesting international jobs with diverse activity and development potentials, which open up an almost endless field of applications, are open to our young skilled workers as they complete their training.





INTERNAL DEPARTMENTS

Reliable basis for our corporate success

The principles of a team sport also apply in a special way to companies. Everyone in the company is responsible for both success and failure. Each and every individual makes a contribution to our company's success. Especially the areas and departments that do not always have a direct connection to customer focus.

We recognized and encouraged accordingly their importance to the company at an early stage. And so logistics was quickly considered to be an integral part of the economic process. We guarantee quality, which is demanded by the company and by you as the customer in equal measure, by a close-knit quality management strategy at GROB.

Even the company suggestion scheme has developed to become a modern ideas management system and the in-house, well-equipped medical service has become known far beyond the company boundaries through its activities and focus on health management.

We are developing special methods of process and cost optimization. Our work in the "GROB Production System (G-PS)" is pioneering. G-PS describes methods and principles that make an important contribution to the advancement of our products and processes throughout the company as a whole.





UNIVERSAL MACHINING CENTERS

Precision at the highest level

Drawing on extensive development expertise from the system business, our engineers have developed a 5-axis universal machining center for all machine tool users. The tried and proven G-module technology – drawing on experience and insights from the automotive industry – has been transferred to the G350, G550 and G750 machine concept. Other innovative developments, such as the non-hydraulic machine tool, the mill-turn machining center, the G1050 and the GROB rotary pallet storage system (PSS-R) quickly achieved success in the highly-competitive market for universal machining centers and rose to the top of their class.

Our G-module series have a common structure and design across all assemblies. They fulfil the flexible requirements of the most diverse sectors, including mechanical engineering, tool and mold industries, automotive, aerospace, as well as medical and energy technology.





SYSTEM SOLUTIONS

The G-series – the flexible manufacturing system

System expertise, coupled with the latest technology, permit customized total solutions in GROB large-scale series production. We offers complete system solutions in the form of individualized production lines. These lines consist primarily of modular machining centers and special-purpose machines that are interlinked with the latest automation solutions.

From planning to engineering, implementation and commissioning through to final acceptance – we provide all services in-house.

Using the latest planning methods and simulation techniques, all systems and processes are refined and optimized down to the very last detail. Our GROB systems are internationally renowned in the automotive industry thanks to the highest possible quality and reliability.

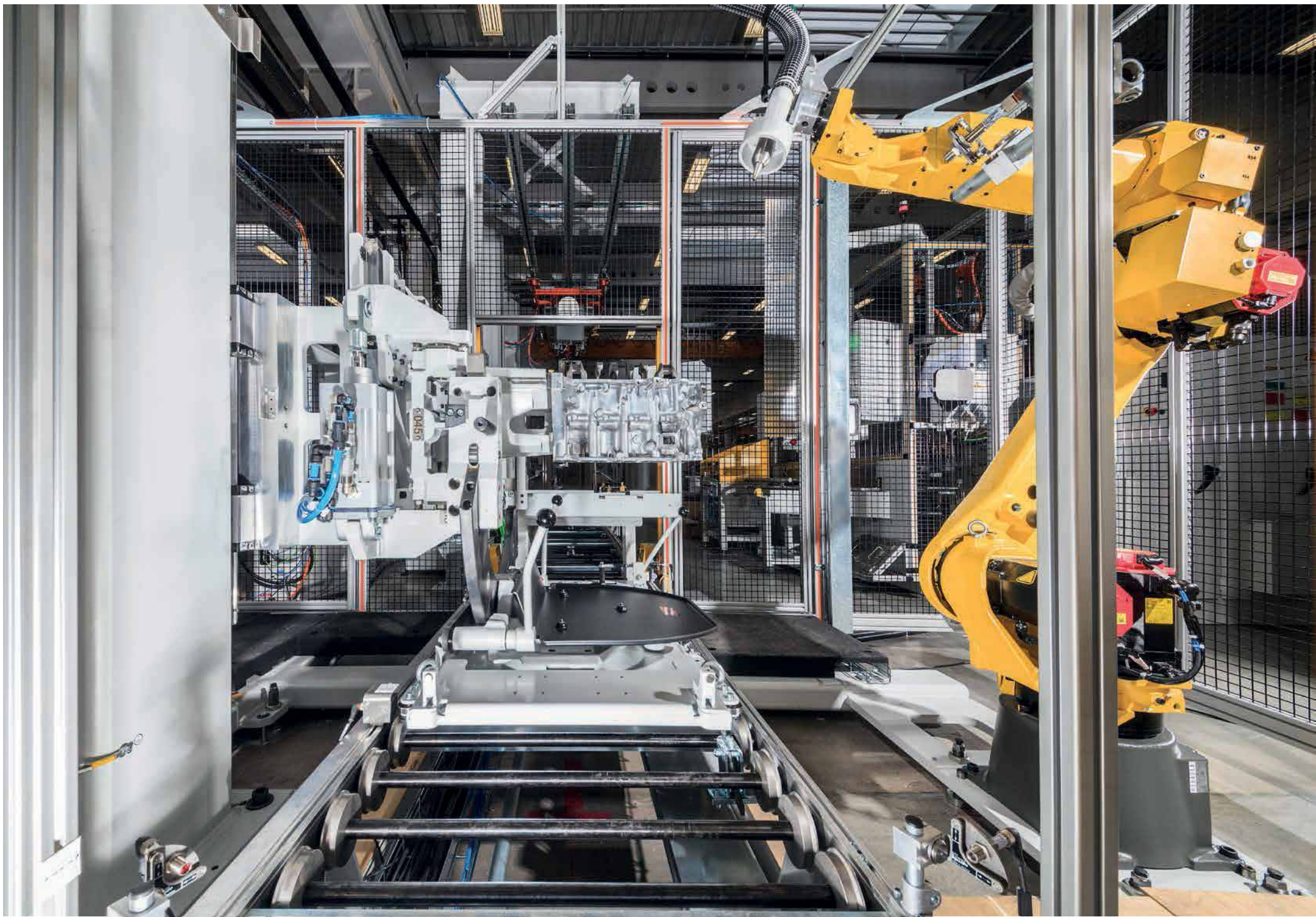



ASSEMBLY SYSTEMS

Highly-productive and customer-specific

We have years of experience in the conceptual design of assembly lines for the assembly technology sector. All assembly stations and assembly lines are individually planned, designed and custom-built according to your specific requirements. Typical assemblies are engines and cylinder heads, as well as automatic and manual transmissions for passenger cars and trucks produced in medium and large volumes.

Our assembly technology systems are largely modular. Individual stations can be assembled with the relevant intermediate automation systems to create entire assembly lines capable of meeting your cycle time requirements.

All the stations are standardized in terms of their configuration, feed and automation systems. This allows us to realize highly-complex assembly lines quickly and cost-efficiently.

GROB-NET

4 INDUSTRY

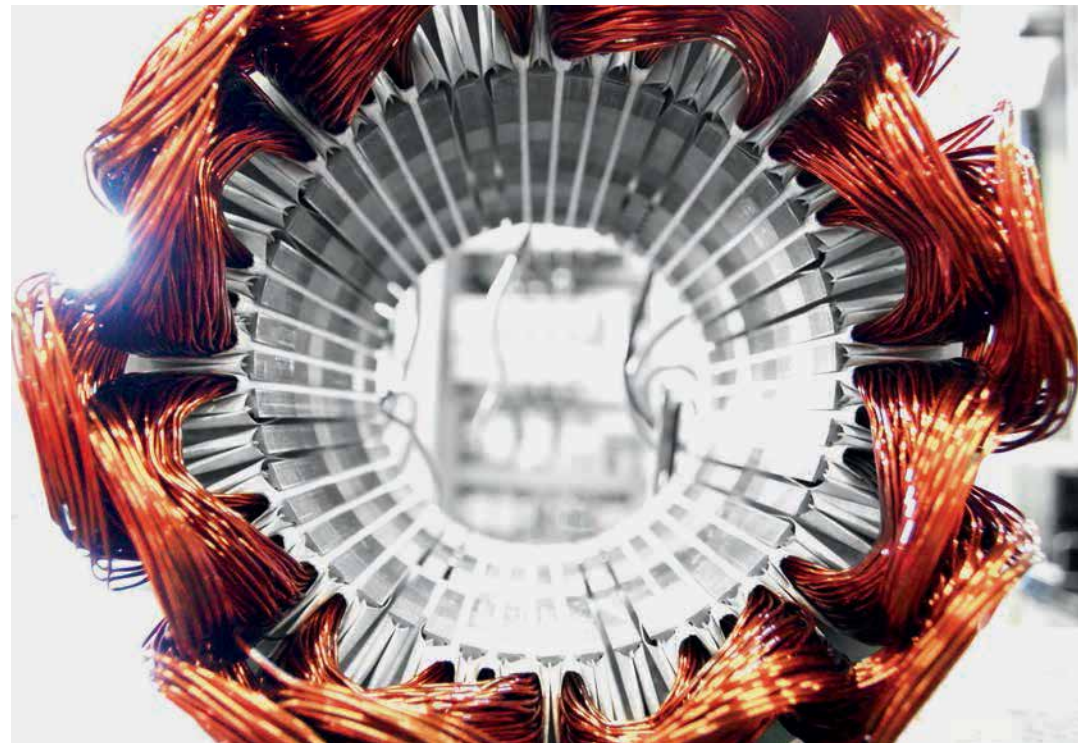

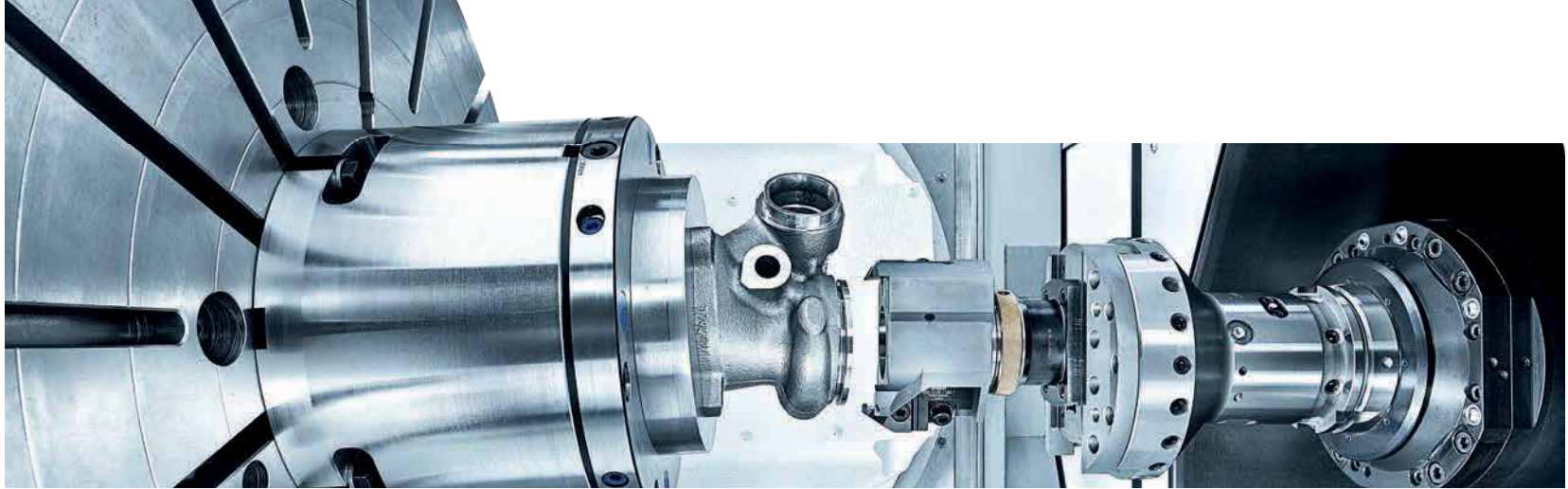

SOPHISTICATED CUTTING-EDGE TECHNOLOGY

Made by GROB

The development of new technologies has been a key element of our success since the very beginning. New technologies that set benchmarks in the mechanical engineering sector are continuously emerging.

And our development department is facing the challenges presented by technological change each and every day. Our engineers are delivering solutions for the thermal spraying technology of engine components, in cutting high-strength turbine housings and machining framework, structural and chassis components. We are also stepping up our research work in electromobility and developing solutions for the entire drive train of hybrid and pure electric drives. This includes plant and machinery for producing electric motors, battery modules, battery packs and fuel cells. In the Industry 4.0 era, we are taking a giant leap into the digital future by developing GROB-NET⁴Industry, our proprietary industrial software, and hence enabling the digitalization and networking of production systems.



OUTSTANDING

Quality –
convinces our customers,
creates recognition and trust

Our highest and most important proof of quality is your praise. In your purchase decision, you are setting extremely special quality standards. GROB quality, recognized and confirmed not least by the numerous recognitions and awards from most of the world's large automotive manufacturers.

Technical expertise coupled with high creativity and the absolute determination to produce precision work are the cornerstones of our GROB products and services. Cornerstones that stand for optimized quality and reliability.

Further proof of GROB quality are the regular reviews of the high, corporate quality standards. All GROB plants, for example, are certified to DIN EN ISO 9001 (Quality Management System) and to DIN EN ISO 14001 (Environmental Management System).

AWARDS

for GROB-WERKE

BOSCH GMBH	
2001/2002	Distinction for quality and particular service as a supplier
2003/2004	
2011/2012	

CHERY AUTOMOBILE CO., LTD	
2012	Chery Best Partner Award

DAIMLER CHRYSLER AG	
1999	Award for excellent performance
2000	
2002	Global Supplier Award – „Top Supplier“
2004	

DAIMLER CHRYSLER CORP.	
1999	Commodity Award for the Mindelheim plant Gold Award for the Mindelheim plant
2000	Commodity Award for the Bluffton plant Gold Award for the Mindelheim plant

DAIMLER AG	
2011	Daimler Supplier Award

GEELY HOLDING GROUP	
2016	Best Supplier Award

JOHN DEERE	
2003	Distinction for exceptional support for the motor project S250

FIAT CHRYSLER AUTOMOBILES	
2015	FCA Qualitas Award

FORD MOTOR COMP.	
1998	Q1-Award for the Mindelheim plant
1999	Q1-Award for the Bluffton plant
2002	Q1-Award for Mindelheim and Bluffton plants
2004/2005	Q1-Award for the Mindelheim plant
2013	FSAO Supplier Award for the São Paulo plant
2014	Award of Recognition
2015	World Excellence Award for the São Paulo plant
2016	Award of Recognition
2017	FORD World Excellence Award 2017

GENERAL MOTORS CORP.	
1994 – 1999	Q.S.T.P. Award as Supplier of the Year
2012 – 2016	

SHANGHAI GENERAL MOTORS	
2006	Best Supplier Award
2012	Break-through and Innovations Award
2013	Best Supplier Award
2014	Supplier of the Year Silver
2015	Supplier of the Year Gold
2016	Excellent Supplier Award

VOLVO CAR CORPORATION	
2005/2006	Q1-Supplier Award
2012	Volvo Cars Quality Excellence Award
2013	Volvo Cars Award of Excellence

VOLKSWAGEN GROUP	
1993	Value to the Customer Award for the Mindelheim plant
1994	Value to the Customer Award for Mindelheim and São Paulo plants
1999	Formula Q
2004	Shanghai VW Supplier Award "Golden Cup"
2007 – 2011	VW Group Award
2012	FAW VW Supplier Award
2014	GP Progressive Partner-Award
2017	FAW VW Excellent Supplier Award
2017	Shanghai VW Excellent Supplier Entry

At your service all around the globe.



www.grobgroup.com