

GROB

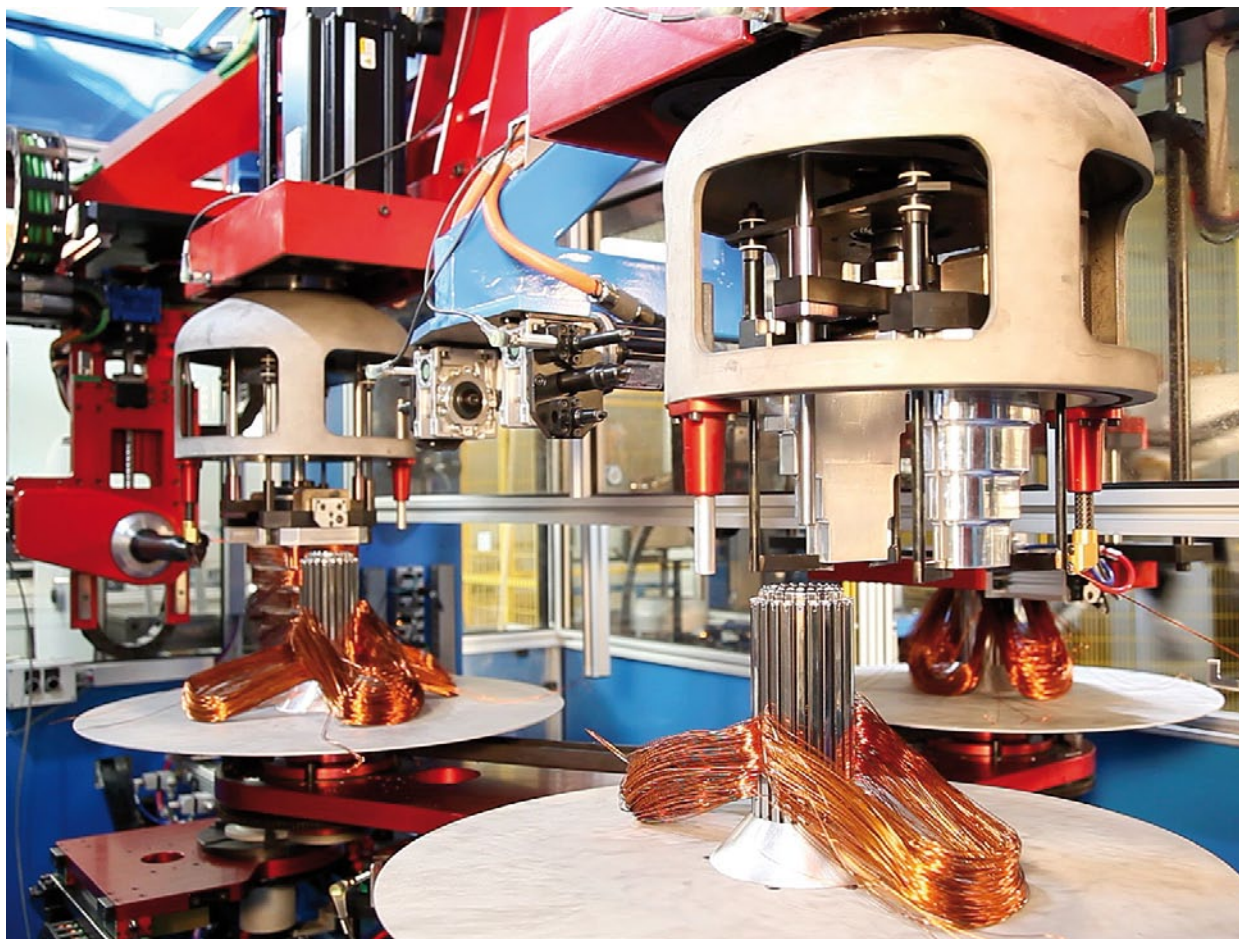
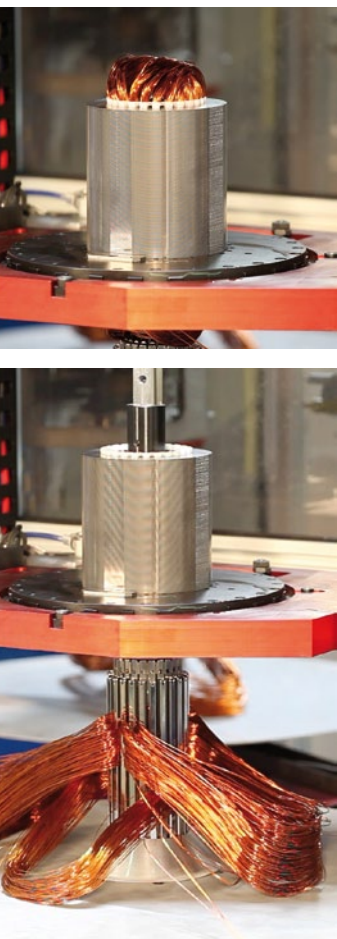

WINDING/INSERTING MACHINE

E200 W12E

TECHNICAL DATA

High efficiency coils insertion with three independent slides
 Automatic adjustment of stack height
 Cuff support to protect slot insulation tape
 Winding speed up to 3000 rpm (optional 4000 rpm)
 Automatic form opening and centering

MACHINE VERSION		E200 W12E
STATOR INTERNAL DIAMETER	mm (min.)	40
	mm (max.)	85
STATOR EXTERNAL DIAMETER	mm (max.)	160
STATOR STACK HEIGHT	mm (min.)	20
	mm (max.)	130
CONCENTRIC COILS	max. n.	8
WIRE DIAMETER	mm (min.)	0.12
	mm (max.)	1.30
MAX. SPINDLE SPEED	rpm	3000
STACK HEIGHT ADJUSTMENT	AUTOMATIC	
WEIGHT OF MACHINE	kg	5000
POWER INSTALLED	kW	40

► E200 W12E

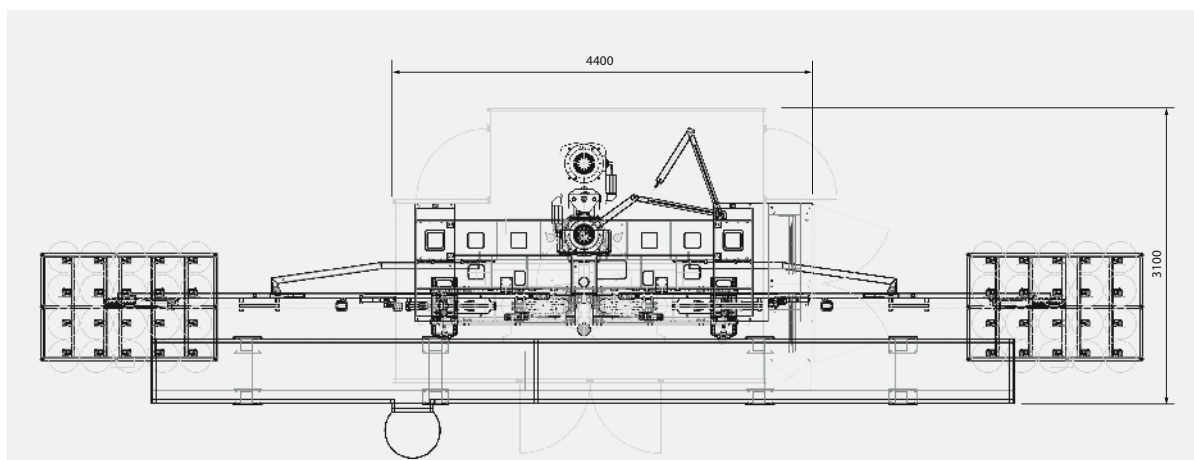

The technical data are indicative, they can be modified at any time due to technical developments by GROB ITALY or according to customer requests.